

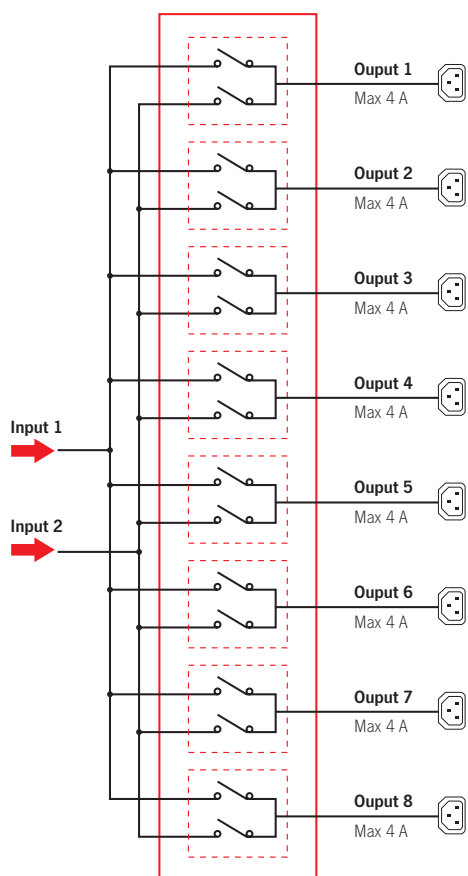

SERVERS

Multi Switch

Multi Switch



Multi-SWITCH improves electrical supply continuity. The principle of operation guarantees a higher reliability level than that achieved using a single UPS (on-line with automatic bypass) or several UPS in parallel.

PRINCIPLE OF OPERATION

The **Multi-SWITCH** provides electrical distribution and remote management for up to eight network users, powered from two direct mains supplies or UPS or a combination of both.

The **Multi-SWITCH** can connect each user (up to eight, each with a maximum power demand not greater than 4A), to either of the two power sources (1 and 2). Load demand is shown on the LCD. See "principle of operation" diagram.

PROTECTION AGAINST POWER SUPPLY FAILURES

If one of the two power source fails or falls outside specification, **Multi-SWITCH** will transfer the connected loads to the second power source (switching is instantaneous even if the two sources are not in phase).

PROTECTION AGAINST LOAD FAULTS

If a fault occurs with one of the loads (for example due to a short-circuit or overload), **Multi-SWITCH** will disconnect the load to prevent disruption to the others. **Multi-SWITCH** protects sensitive installations from both power and hardware faults.

CHARACTERISTICS

- Full protection against mains failures and load faults
- Flexible power sources: Multi-SWITCH can be powered from 2 different sources (2 mains supplies, 2 UPS or a combination of both. Note that the UPS can be of a different size)
- Designed for installation in a 19" rack-mount cabinet
- LCD to provide measurements/alerts/status information
- Management software included
- Remote monitoring serial interface
- No signal connection is required between Multi-SWITCH and the power sources or supplied hardware
- Configuration software provided as standard
- Slot-in SNMP network adapter card

MSW (2 input - 8 output)

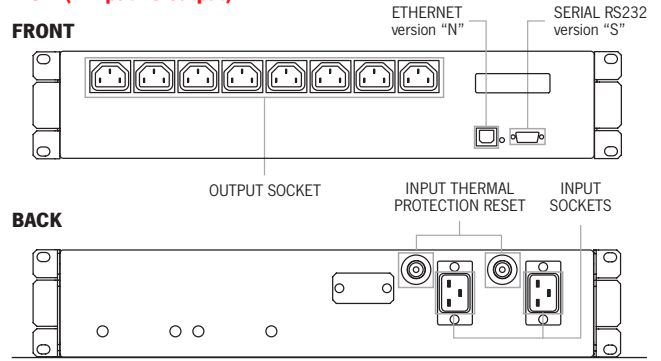

TECHNICAL DETAILS

MODELS	MSW
	8 x 4A output sockets
INPUT	
Input voltage	180 - 276 Vac
Rated frequency	50/60 Hz
Maximum load for each input (A)	16
Input sockets	2 IEC 320 (16A)
OUTPUT	
Output voltage	Selection of one of the two input sources
Maximum load for each output (A)	4
Output sockets	8 IEC 320 10A
ENVIRONMENTAL	
Weight (kg)	10
Dimensions (hwd) (mm)	2U x 19" x 360
Operating temperature	0°C - 40°C
Relative humidity	< 95% non condensing
Protection	Overcurrent - overvoltage - undervoltage - back-feed protection
Safety compliance	EN 62040-1 EMC EN 62040-2 Directives 73/23 - 93/68 - 2004/108 EC EN 62040-3
Maximum altitude	3000 m
Max. altitude (storage conditions)	6000 m; 45 °C
Communication	RS232 in MSW-S / Ethernet in MSW-N
Enclosure protection rating	IP 20
Colour	Dark grey RAL 5004
Noise	< 35 dBA at 1 m

Product characteristics can be customised to meet client specifications.

