



Liquid leak detection system **FG-A Alarm Unit** Technical data

The FG-A alarm unit, connected to a TTK FG-ECX, FG-ACX or FG-HC2 sense cables, is designed for the leak detection of liquids. The presence of a conductive liquid on the sense cable triggers an audible and luminous alarm, and activates dry contacts on the FG-A alarm unit. This detection system fits in perfectly with a safety and protection system. Its two dry contacts ensure fault control and transfer back to a centralized management system.

FG-A Alarm Unit Design

The FG-A alarm unit differentiates between a leak detection and an interruption fault. Two contacts are available which allow this data to be used independently.

Three electro luminescent diodes on the unit indicate presence of supply, leak detection and an interruption fault.

A button on the front panel enables the operator to acknowledge the audible alarm.

Two types of presentation are available: a wall unit (FG-A) and a

rack mounted unit (FG-A19") 19" and 2 U high.

Using The FG-A Alarm Unit

The FG-A alarm unit is supplied automatically with either 12, 24 or 230 volts. The easily accessible terminals centralize the various connections.

In normal operation, the supply diode is on green.

In the event of detecting a leak, an audible alarm is triggered, the "LEAK" diode goes red, and the leak dry contact is activated.

In the case of sense cable circuit failure, an audible alarm is triggered, the "CABLE BREAK" diode changes to yellow and the interruption contact is activated.

In both cases, the operator must stop the audible alarm by pressing once on the button. The red or yellow diode and corresponding contacts remain activated as long as the fault persists – when this disappears, the diode goes out and the contact returns to its original normal status.

The Applications of The FG-A Alarm Unit

The FG-A alarm unit can be used for the protection of small computer rooms or technical premises. Under-window air-conditioning units, fan-convectors, reservoirs, pumps, siphons, tanks, etc. are the main applications of the FG-A leak detection system.

This system allows immediate detection of all leaks of conductive liquids (water, acids, alkaline, hydrocarbons or solvents). FG-A is compatible with any type of FG-ECX, FG-ACX or FG-HC2 sense cable from TTK; it should be controlled by a monitoring or operating system.

A potentiometer for adjusting sensitivity of detection is available on the units connecting circuit.

We recommend a twice-yearly control of the FG-A alarm unit.

FG-A alarm unit meets requirements of the European Standards in EN 50081 and 50082 EMC.



FG-A Alarm Unit

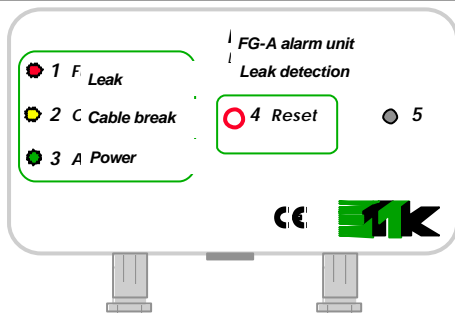

- 1: The leak signal (red diode goes on) indicates that the system has detected a liquid leak.
- 2: The continuity signal (yellow diode goes on) indicates that the system has detected a circuit interruption.
- 3: The power supply signal (green diode on) indicates that the system is in normal operation.
- 4: The button is used to stop the audible alarm triggered in case of fault.

Connector Descriptions

All the connections in the FG-A alarm unit must be done with the power supply switched off.
Read carefully the installation procedure for the FG-A alarm unit.

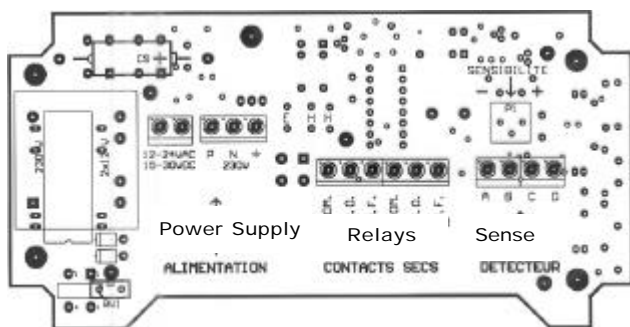

- * Power supply 230-240 V ca: N : neutral
P : phase
⊥ : earth
- * Power supply 12 V or 24 V ca/cc: (no need to follow the polarity)
- * Power fault or continuity fault relay:
: COM
: NO
: NC
- * Leak relay: : COM
: NO
: NC
- * FG-CLC leader cable:
A : Green wire
B : White wire
C : Black wire
D : Red wire
- * Potentiometer P1 for adjusting sensitivity of detection

Technical Information

Fixed Unit

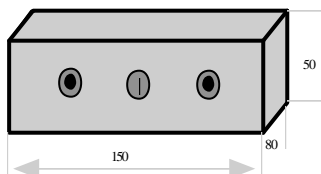

Encased Unit 19"

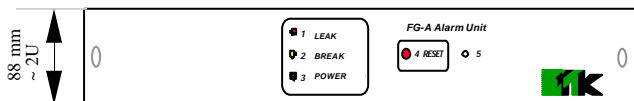

Box type:	ABS box
Box Norma:	IP 50
Working temperature range:	0°C to 50°C
Relays type: leak continuity	single contact NO-NC single contact NO-NC
Maximum voltage:	125V AC and 60V DC
Maximum power:	62,5 VA / 30 W
Maximum capacity:	1 A
Supply voltage:	12, 24 or 220 V.
Dimensions: (w,h,d) FG-A or FG-A19"	150,80,50 mm or 88,483,88 mm

Identification Codes

FG-A (wall Mounted) FG-A 19" FG-A Kit	Alarm unit FG-A fixed Alarm unit FG-A encased unit 19" and 2U high Set of FG-A alarm unit with 3m of sense cable and accessories
Accessories: FG-CLC FG-ECX or FG-ACX FG-HC2	Leader cable of 3 m length Water or acids sense cable in 3m, 7m, and 15m in length Hydrocarbon sense cable in 2m length

This brochure with its photos, illustrations and charts were carefully prepared, but may only be taken as examples. TTK UK Ltd cannot guarantee that the information given contains no errors or omissions and will accept no responsibility related to the usage of its equipment. TTK's only obligations are those set forth in the Standard Terms and Conditions of Sale and will not under any circumstances be held liable for any incidental, indirect or consequential damages arising from the sale, resale or misuse of this product. The purchasers are the sole judges of the product's adaptability to the use for which it is destined. **FROGSYS** and **TOPSurveillance** are trademarks of TTK SAS.

FG-A Products:

FG-A_uk5.pub
01.2003

TTK UK Ltd.
26 Elder Street
London
E1 6BT
Tel: 0207 375 0721—Fax.: 0207 375 0748
www.ttkuk.com—Email: sales@ttkuk.com